

[M16ST1101]
 I/II M.Tech. I Semester Regular Examinations
STRUCTURAL ENGINEERING
 MODEL QUESTION PAPER
THEORY OF ELASTICITY

Time: 3 Hours

Max. Marks: 70

Answer any FIVE questions.
 All questions carry equal marks.

1. If the State stress at any point in a body in a three dimensional force system is given by the following equations. 14M

$$\begin{aligned} \sigma_x &= ax + by + cz & \sigma_y &= dx^2 + ey^2 + fz^2 \\ \sigma_z &= gx^3 + hy^3 + iz^3 & \tau_{xy} &= k, \tau_{yz} = ly + mz \\ & & \tau_{zx} &= nx^2 + pz^2 \end{aligned}$$

What equations must the body forces, F_x , F_y and F_z satisfy for equilibrium.

2. Prove the following relationships. 14M

$$(a) (\sigma_n)_{OCT} = \frac{1}{3}(\sigma_1 + \sigma_2 + \sigma_3)$$

$$(b) \tau_{OCT}^2 = \frac{1}{9}[(\sigma_1 - \sigma_2)^2 + (\sigma_2 - \sigma_3)^2 + (\sigma_3 - \sigma_1)^2]$$

3. By means of strain rosette, the following strains were recorded during the test on a structural member. 14M

$$\epsilon_0 = -13 \times 10^{-6} \text{ mm/mm}$$

$$\epsilon_{45} = 7.5 \times 10^{-6} \text{ mm/mm}$$

$$\epsilon_{90} = 13 \times 10^{-6} \text{ mm/mm}$$

Determine:

- (a) Magnitude of principal strains.
 (b) Orientation of principal Planes.

4. Given the stress function $\phi = \left(\frac{H}{\pi}\right) z \tan^{-1}\left(\frac{x}{z}\right)$

Determine whether stress function ϕ is admissible. If so determine the stresses. 14M

5. Investigate what problem of plane stress is satisfied by the stress function.

$$\phi = \frac{3F}{4h} \left(xy - \frac{xy^3}{3h^2} \right) + \frac{py^2}{2}$$

Applied to the region included in $y=0$, $y=h$, $x=0$ on the side x positive. 14M

6. (a) Define AIRY's stress function. 4M
(b) Derive equilibrium equations in two dimensional polar coordinates. 10M
7. Starting from stress function, derive an expression for stress components in a thick cylinder of internal radius 'a' and an external radius 'b' subjected to both Internal pressure p_i and external pressure p_0 . 14M
8. Write short note on the following 14M
- (a) Lamé's constants
 - (b) Saint-Venant's Principle.
 - (c) Use of Polynomials in the solution of structural Problems.

[M16ST1101]

[M16ST1102]
I/II M.Tech. I Semester Regular Examinations
STRUCTURAL ENGINEERING
MODEL QUESTION PAPER
ADVANCED REINFORCED CONCRETE DESIGN

Time: 3 Hours

Max. Marks: 70

Answer any FIVE questions.
All questions carry equal marks.
Use of I.S . 456-2000 Code is permitted.

1. (a) Distinguish between short term and long term deflections. Why is it necessary to limit deflections in R.C. flexural members. [6]
(b) A simply supported reinforced concrete beam of T-shaped cross section with a flange width of 1500 mm, flange thickness of 100mm and web width of 250mm is reinforced with 8 bars of 16 mm dia on the tension side at an effective depth of 600mm. Determine the short term maximum deflection if it is subjected to total service load of 45 kN/m, when used over an effective span of 6.5m. Use M20 grade concrete and Fe 415 grade steel. [8]
2. (a) What are the major factors which influence crack widths in flexural members. [4]
(b) A simply supported beam having 6.5 m span is 500mm X 700 mm in cross section. It carries a superimposed dead Load of 35kN/m and live load of 45kN/m at service. Calculate the design surface crack width
(i) Under a bar on the tension face.
(ii) At a point on a side face 200 mm below the neutral axis. [10]
3. (a) Explain the bases underlying the various limitations imposed by the code with regard to moment redistribution. [4]
(b) A two span continuous beam 6m each carries a characteristic dead load of 15 kN/m and characteristic live load of 20 kN/m. Determine the ordinates of the bending moment diagram at every one sixth point by considering maximum redistribution of moments. [10]
4. A reinforced concrete grid floor of size 9m x 13.5 m is required for a function hall. The floor is subjected to a live load of 4 kN/m². Take the rib spacing of 1.5 m in both the directions. Design the grid floor using M20 grade concrete and Fe 415 grade steel. Sketch the reinforcement details. [14]
5. Design a Silo for storing maize, having unit weight of 6870 N/m³. The Silo has 6 m internal diameter and the height of the cylindrical portion is 15 m. The conical dome has a slope of 40° with horizontal, and has an opening of 60 cm diameter. Use Airy's theory. Take $u=0.521$ and $u^1=0.432$. Use M 20 grade concrete. [14]
6. Design a Chimney of 30 m height, having external diameter of 2.6 m throughout the height. The chimney has a fire brick lining of 100 mm thickness, provided up to a height of 24 m above base, with an air gap of 100mm. Assume the temperature of gases above the surrounding air as 240° C. Take α for R.C.C as 11×10^{-6} per °C and $E_s=2.05 \times 10^5$ N/mm². Use M20 grade concrete. [14]

7. Design a rectangular beam for 8 m span to support a dead load of 12kN/m and a live load of 15kN/m Inclusive of its own weight. Moment due to earth-Quake load is 120 kNm and shear force is 90 kN. Use M20 grade concrete and Fe 415 grade steel. [14]
8. Write short notes on any Two of the following: [14]
- (a) Effect of high temperature on steel and concrete
 - (b) Moment Curvature relation of R.C Sections
 - (c) Fire Resistance ratings
 - (d) Flat slab design by Direct design method.

[M16ST1102]

[M16ST1103]
 I/II M.Tech. I Semester Regular Examinations
STRUCTURAL ENGINEERING
 MODEL QUESTION PAPER
MATRIX METHODS OF STRUCTURAL ANALYSIS

Time: 3 Hours

Max. Marks: 70

Answer any FIVE Questions.
 All questions carry equal marks.

1. Develop the flexibility matrix for the given beam [Figure.1] with reference to the co-ordinates shown. EI is constant. [14 M]

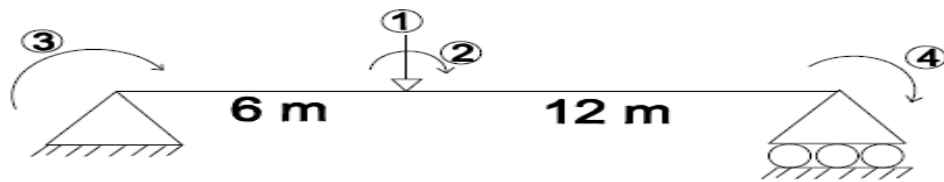

Figure 1

2. Develop the stiffness matrix for the given beam [Figure.2] with reference to the co-ordinates shown. EI is constant. [14 M]

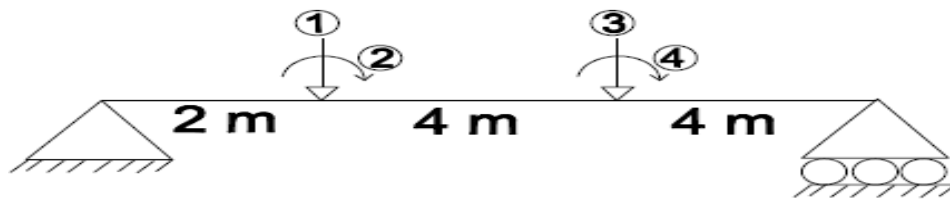

Figure 2

3. Analyse the continuous beam using force method treating the support reaction at 'C' as redundant [Figure.3]. Hence find the support reaction at A. Also Draw B.M.D. [14 M]

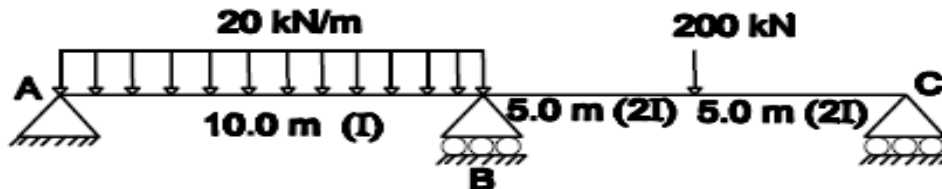

Figure 3

4. Analyse the beam using displacement method [Figure.4]. Hence find support reaction at 'A'. Also draw B.M.D. [14 M]

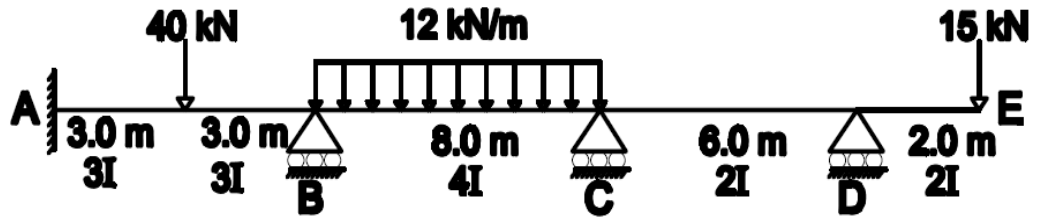

Figure 4

5. Find the forces in the members of the truss using Force method. AE is same for all the members. [Figure.5] [14 M]

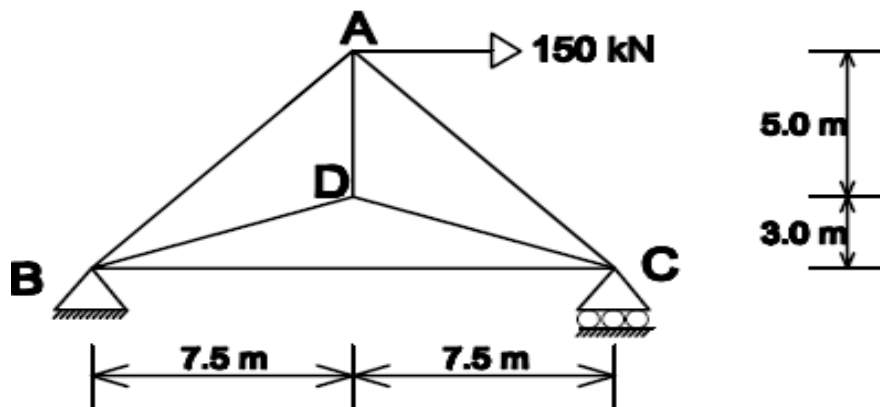

Figure 5

6. Find the forces in the members of the truss using Displacement method [Figure.6] [14 M]

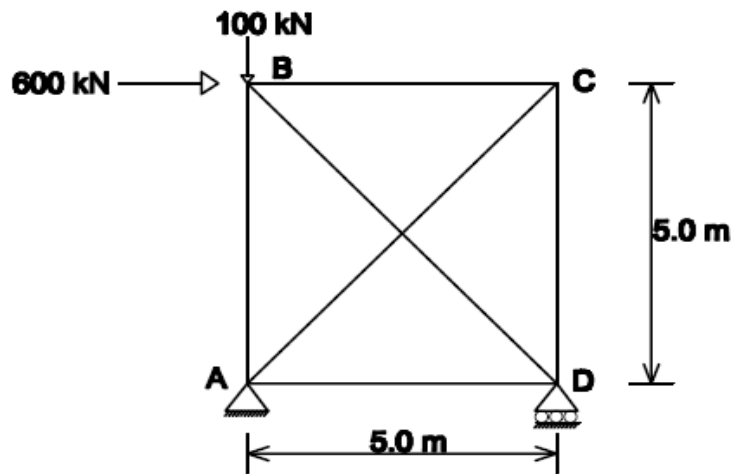

Figure 6

The axial stiffness of each member is 500 kN/cm.

7. Analyse the given frame using flexibility method. Also draw B.M.D. [Figure.7]
[14 M]

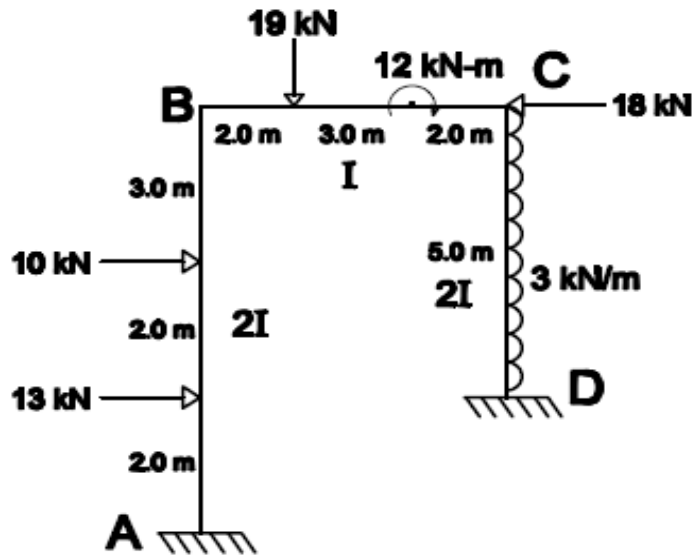

Figure 7

8. Analyse the following frame a [Figure.8] using stiffness Method. Also draw B.M.D. [14 M]

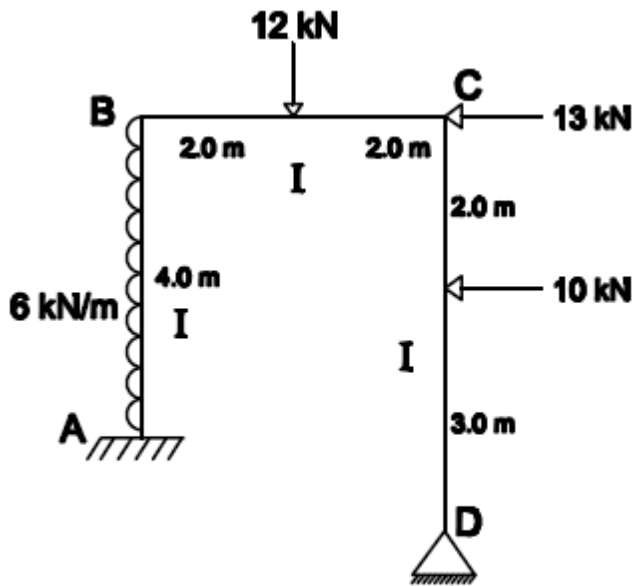

Figure 8

[M16ST1104]
 I/II M.Tech. I Semester Regular Examinations
STRUCTURAL ENGINEERING
 MODEL QUESTION PAPER
STRUCTURAL DYNAMICS

Time: 3 Hours

Max. Marks: 70

Answer any FIVE questions.
 All questions carry equal marks
 Assume missing data if any suitability.
 Use of relevant codes permitted.

1. Derive the general governing differential equation for damped free vibration of single degree Freedom system [Spring-mass-dashpot] and discuss the motion of the mass for different values of damping. [14 M]
2. (a) A simply supported beam of span '1' with flexural rigidity EI is carrying weight 'W' at the centre of the span. Compute the natural period and natural Frequency. [7M]
 (b) A weightless truss is subjected to a single mass 'm' as shown in Figure 1. Compute the natural period for the system in terms of m, l, E and A by representing the structure as a spring mass system. [7 M]

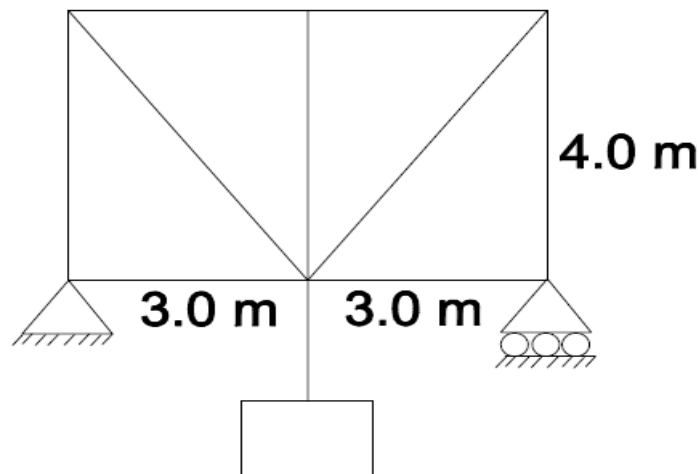

Figure 1

3. Name various modeling techniques of dynamically loaded structures. Also discuss their relative merits and demerits. [14 M]
4. (a) The stiffness matrix and mass matrix of two degree system are given by

$$k = \begin{bmatrix} 8 & 7 \\ 7 & 8 \end{bmatrix} \text{ and } m = \begin{bmatrix} 1 & 0 \\ 0 & 1 \end{bmatrix}$$

Using Stodola-Vianello, determine the natural frequencies and corresponding modes of vibrations, normalized with respect to, matrix such that $y^t m y = 1$. [7 M]

(b) Reduce the above system to a systems of the independent differential equations by decoupling the variables by normal mode method. [7 M]

5. A simply supported ISWB 600 @ 1.38kN/m steel beam has a span of 7m and a total dead weight of 40kN/m under adynamic yield strength of 350MPa. Determine the maximum dynamic deflection due to loads at the third points of the span each having a rise time of 0.05 sec and a constant value thereafter of 500 kN. What is the maximum dynamic beam reaction? [14 M]

6. Determine the natural frequencies and mode shapes of the framed structure shown in Figure 2. The floor is considered to be absolutely rigid. [14 M]

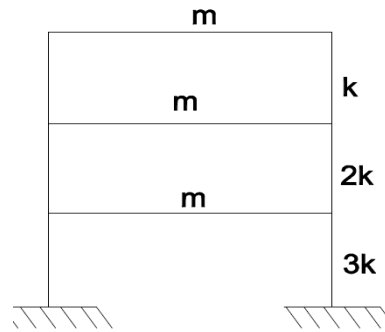

Figure 2

7 (a) What is an idealized system? Explain briefly with at least two examples. [7 M]

(b) Explain the approximate design procedures of multi-degree system with example. [7 M]

8. For the system shown in Figure 3, write the frequency equation in terms of M_1 , M_2 , E_1 , I_1 and K_s . Neglect the mass of the beams. [14 M]

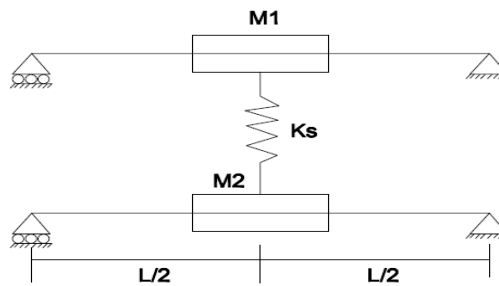

Figure 3

[M16ST1104]

[M16ST1105]
I/II M.Tech. I Semester Regular Examinations
STRUCTURAL ENGINEERING
MODEL QUESTION PAPER
ADVANCED FOUNDATION ENGINEERING

Time: 3 Hours

Max. Marks: 70

Answer any FIVE questions.
All questions carry equal marks
Assume missing data if any suitability

1. (a) Different between Terzaghi's and Meyerhof's bearing capacity theories briefly. [7M]
(b) What is standard penetration number? Explain various corrections applied to it. [7M]
2. (a) What is differential settlement? Explain various measures that are to be practised to avoid it. [7M]
(b) A strip footing on dense sand is required to carry a safe load of 1000 kN at a depth of 1 m. Taking a factor of safety of 3, determine the width of the footing. Take $N_c = 55$, $n_q = 38$, $n = 45$ and unit weight of sand as 20 kN/m^3 . Assume water table is at deeper location. Use Terzaghi's bearing capacity theory. [7M]
3. (a) What is modulus of sub grade reaction? Explain how it is to be determined. [7M]
(b) Discuss briefly the effect of water table on bearing capacity of soils. [7M]
4. (a) Explain various dynamic formulae and their limitations briefly. [7M]
(b) A group of 16 piles of 600 mm diameter arranged in a square pattern with centre to centre spacing of 1.2 m long and are embedded in stiff clay with a cohesion of 100 kN/m^2 . Determine ultimate bearing capacity of the pile group by neglecting end-bearing resistance. Assume adhesion-factor as 0.5. [7M]
5. (a) Explain the following parameters and their significance briefly. [7M]
(i) Active depth. (ii) Swell potential
(b) What are under-reamed piles? Explain their construction briefly. [7M]
6. (a) Describe various components of a pneumatic caisson with the help of a sketch. [7M]
(b) How would you estimate load carrying capacity of an open caisson? [7M]
7. (a) What are the forces considered in the design of Tower foundation? Explain them briefly. [7M]
(b) On what factors Tower foundation depends and explain Grillage and reinforced concrete footing briefly. [7M]
8. Write short notes on any Three of the following: [14 M]
(a) Classification of piles (b) Pile load test
(c) Tilts and shifts in well foundations (d) Types of Raft foundations

[M16ST1105]

[M16ST1106]
I/II M.Tech. I Semester Regular Examinations
STRUCTURAL ENGINEERING
MODEL QUESTION PAPER
WIND ANALYSIS AND DESIGN OF TALL STRUCTURES

Time: 3 Hours

Max. Marks: 70

Answer any FIVE questions.
All questions carry equal marks
Assume missing data if any suitability

1. A multi- storeyed building has following data. [14M]

Building	- GF+5 upper floor (7 stories).
Plan dimensional of typical floor	- 20mx30m.
Column grid	-5mx5m.
Typical floor height	- 4.5m.
Ground floor height	- 5.0m.
Ground level	- +-0.0.
Ground beam top	- 0.2m.
Footing top level	-1.8m
All beams including ground beams	- 250mmx500mm.
Location	- Outskirts of city where at is surrounded by building of its heights.
Basic Wind Speed	- 44m/s.
Slab thickness	- 120mm thick
Floor beams	- 200mmx500mm, so that slab spans 2.5m.
Live load	-1100/m ² .
External periphery walls	- 5100/m ² .
Internal partition wall(wooden)	- 1kN/m ²
Corner columns	- C ₁
External columns	-C ₂
Internal columns	- C ₃
Parapet on terrace	- 1m(5kN/m).

- (a) Determine the design wind pressure acting on the building
- (b) Draw the wind pressure diagram to be used for analysis if the building is un-braced.
- (c) Draw the wind pressure diagram to be used for analysis if the building is braced by four shear walls placed on external periphery in central bays on all four sides.
2. Design a chimney of 66m height, having external diameter of 4m throughout the height. The chimney has fire brick lining of 100mm, thickness provided upto a height of 42.3 m above ground level, with an air gap of 100mm. The temperature of gases above surrounding air is 200°C, and $E_s=2.05 \times 10^5 \text{N/mm}^2$. Use M₂₅ grade concrete mix [14M]

3. Analyse the frame in fig-2 by factor method to get moments in girders and columns of top story. [14M]

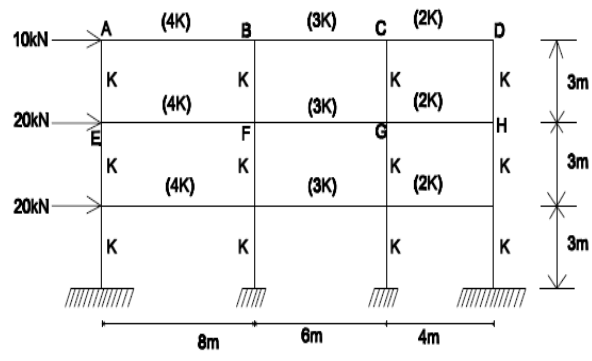

Figure 2

4. Analyse the frame in fig-3 by cantilever method [14M]

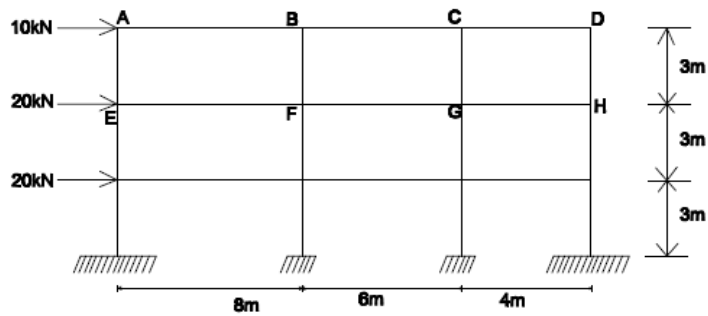

Figure 3

5. Design the side walls and hoper bottom of a 3mx3m saure bunker to store 30 tones of coal. density of coal is 9 kN/m. Angle of repos3e i9s 30°. Adopt M20 grade concrete and Fe415 HYSD bars. Sketch the details of reinforcement 9 the bunkers. [14 M]

6. A cement Silo has an internal diameter of 10m with the height of cylindrical portion being 30m. The density of cement is 15.2 KN/m³. Co-efficient of friction between concrete and material is 0.70. The angle of repose 0of the material is 17.5 de3grees. Adopting M20 grade concrete and Fe 415 HYSD bars, design the thickness and the reinforcement required at the bottom of the cylindrical portion of the Silo using Janssens theory. [14 M]

7. Analyse the intermediate frame of multistoried from shown in fig.1

[14 M]

Spacing of gram	= 3.6m
Dead load on floor	= 4kN/m ²
Live load on floor	= 3kN/m ²
Self weight of beams	= 5kN/m for beams of span 9m = 4kN/m for beams of span 6m = 3kN/m for beams of span 3m.

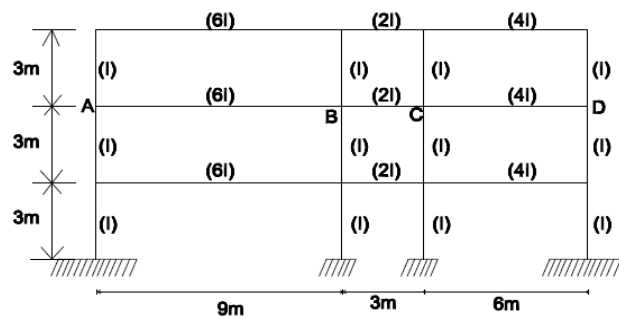

Figure 1

8. Write short notes on any Two of the following:

[14 M]

- Explain the portal method for analyzing a building frame subjected to horizontal force
- Derive an expression for temperature stresses in horizontal reinforcement of a R.C chimney.
- Distinguish clearly between a bunker and silo using Airy's theory, show that the height up to which a bin behaves as a shallow one is given by

$$h = b \left[\mu + \sqrt{\frac{\mu(1 + \mu^2)}{\mu + \mu'}} \right]$$

[M16ST1106]

[M16ST1107]
I/II M.Tech. I Semester Regular Examinations
STRUCTURAL ENGINEERING
MODEL QUESTION PAPER
EXPERIMENTAL STRESS ANALYSIS

Time: 3 Hours

Max. Marks: 70

Answer any FIVE questions.
All questions carry equal marks
Assume missing data if any suitability

1. Describe a method for the determination of Poisson's ratio of a material experimentally using strain gauges 14M
2. How are the strain gauges calibrated? 14M
3. Describe a method for determining stress using Iso-chromatic fringes in photo-elasticity. Mention the advantages of this method over other methods? 14M
4. Explain the circularly polarized light in photo-elasticity? 14M
5. Write short notes on
 - (i) Brittle lacquer method of stress analysis. 7M
 - (ii) Calibration of strain gauges. 7M
6. Explain in detail Determination of dynamic stresses. 14M
7. Explain in detail Isoclinics in photo-elasticity 14M
8. Explain the necessity of compensation in photoelastic studies. What are the different techniques used in compensation? 14M

[M16ST1107]

[M16ST1108]
I/II M.Tech. I Semester Regular Examinations
STRUCTURAL ENGINEERING
MODEL QUESTION PAPER
ADVANCED CONCRETE TECHNOLOGY

Time: 3 Hours

Max. Marks: 70

Answer any FIVE questions.
All questions carry equal marks.

- 1). Explain the following types of cement highlighting how it is different from Ordinary Portland cement in composition, properties and uses:
 - (a) Low Heat Cement
 - (b) Sulphate Resisting Cement
 - (c) High Alumina Cement
 - (d) Air Entraining Cement
 - (e) Hydrophobic Cement (14 M)
- 2). what is creep and shrinkage of concrete? List the factors affecting creep and shrinkage of concrete. (14 M)
- 3). List and explain the various factors affecting the strength of concrete. (14M)
- 4). what is Mix Design? Explain in detail the various factors governing the selection of Mix proportion (14 M)
- 5). Explain the various methods of transportation of concrete. (14 M)
- 6). Explain the classification of light weight aggregates (14 M)
- 7) Explain the characteristics of and uses of fibre reinforced concrete. (14 M)
- 8). Discuss the manufacture; properties and applications of polymer concrete. (14 M)

[M16ST1108]

[M16ST1109]
I/II M.Tech. I Semester Regular Examinations
STRUCTURAL ENGINEERING
MODEL QUESTION PAPER
BRIDGE ENGINEERING

Time: 3 Hours

Max. Marks: 70

Answer one Question from Part A and remaining two questions from part B

Use of IS codes and IRC codes permitted

PART A

1. a) Explain the factors to be considered while selecting a suitable site for a bridge. **(5 marks)**
- b) Design a slab culvert for the following data: Effective span = 4.5m, Clear width of carriage way = 7.5m, Thickness of wearing coat = 70 mm, provide foot path of 750mm wide on either side, Loading IRC Class A, Use M20 concrete and Fe415 steel. Design and detail the slab bridge. **(25 marks)**

Or

2. a) Design a box culvert for the following data: Inside dimensions of box culvert = 3m × 3m
Super imposed dead load on box culvert = 12kN/m² Live load on box culvert = 40kN/m²
Unit weight of soil = 18kN/m³, ϕ of soil = 30°, Use M20 concrete and Fe415 steel
Consider only one load combination: DL+LL while no water inside the drain. **(25 marks)**
- b) Explain with sketch the different types of bridges. **(5 marks)**

PART B

3. Design the longitudinal in all girder of a T beam slab bridge for the following data: Effective span = 17m, width of carriage way = 7.5m, thickness of wearing coat = 80mm, width of kerb = 600mm on either side, Live load: IRC Class AA tracked vehicle, Use M25 concrete and Fe415 steel, Assume 3 longitudinal girders and 7 cross girders. Use Courbon's method. **(20 marks)**
4. Design the mid span cross section of longitudinal girder of a simply supported prestressed concrete T beam slab bridge for an effective span of 27m. Assume IRC Class AA tracked vehicle as live load, width of carriageway = 7.5m, thickness of wearing coat = 80mm, width of kerb = 600mm on either side. Provide 3 longitudinal girders and 9 cross girders. Use M35 concrete. Provide necessary sketches of cross section and cable profile. **(20 marks)**
5. Design an elastomeric bearing of a bridge for the following data. Maximum normal load = 1200kN, Minimum normal load = 500kN, Transverse lateral load = 40kN, Longitudinal load = 50kN, total longitudinal translation = 17mm, rotation to be allowed at support is 0.003 rad. Shear modulus of elastomer = 1.2 N/mm², Allowable compressive stress for concrete = 7.5N/mm², Allowable compressive stress for elastomer = 12N/mm². Sketch the details. **(20 marks)**

[M16ST1109]

[M16ST1110]
 I/II M.Tech. I Semester Regular Examinations
STRUCTURAL ENGINEERING
 MODEL QUESTION PAPER
OPTIMIZATION TECHNIQUES

Time: 3 Hours

Max. Marks: 70

Answer any FIVE questions
 All questions carry equal marks.

- 1(a) How the optimization problems classified and describe them briefly. [7 M]
 (b) Explain the statement of an optimization problem. [7 M]
2. Minimize $f(x)=1/2(x_1^2+x_2^2+x_3^2)$ [14 M]
 Subjected to $g_1(x)=x_1-x_2=0$
 $g_2(x)=x_1+x_2+x_3-1=0$
 By (i) direct substitution (ii) Lagrange multiplier method.
3. (a) Define Fibonacci numbers. What is the difference between?
 Fibonacci and golden section methods. [7 M]
 (b) Find the minimum of $f = \lambda^5 - 5\lambda^3 - 20\lambda + 5$ by the quadratic interpolation
 method. [7 M]
4. (a) Maximize $Z=2x_1-x^2+x_2$ subjected to $2x_13x_2 \leq 9$, $x_1, x_2 \geq 0$ where x_1 and x_2 are both
 integers, by dynamic programming. [7 M]
 (b) Explain normality condition in geometric programming. [7 M]
5. Minimize $f(x)=x_1^2+x_2^2-6x_1-8x_2+10$ [14 M]
 Subjected to $4x^2+x_1^2 \leq 16$
 $3x_1+5x_2 \leq 15$
 $x_1 \geq 0, i=1,2$
 By using the Zoutendijk's method with the starting point $x_1 = \begin{Bmatrix} 1 \\ 1 \end{Bmatrix}$
6. (a) Show that DEF method is a conjugate gradient method.. [7 M]
 (b) Minimize $f=4x_1^2+3x_2^2-5x_1x_2-8x_1$
 Starting from the point (0,0) using Newtons method. [7 M]
7. (a) State and explain Khun-Tucker conditions for optimality. [7 M]
 (b) Maximize $Z=4x_1+6x_2-2x_1^2-2x_1x_2-2x_2^2$
 Subjected to the constraints $x_1+x_2=2$ and $x_1, x_2 \geq 0$. use Khun-Tucker conditions. [7 M]
8. Write short notes on: [14 M]
 (a) Differential calculus method
 (b) Plastic design.
 (c) Quadratic interpolation method.
 (d) Design of frames by dynamic programming.

[M16ST1110]

[M16ST1201]
I/II M.Tech. II Semester Regular Examinations
STRUCTURAL ENGINEERING
MODEL QUESTION PAPER
THEORY OF PLATES AND SHELLS

Time: 3 Hours

Max. Marks: 70

Answer any FIVE questions.
All questions carry equal marks.

1. (a) Derive an expression for the deflection of long rectangular plates with simply supported edges subjected to cylindrical bending. State the basic assumption involved. [10 M]
(b) A 2mx8m plate resting on simply supported edges is subjected to a load of kN/m^2 . If the thickness of the plate is 25mm, determine the maximum mid span deflection of the plate if $E=2.1 \times 10^5 N/m^2$ and $\nu=0.25$. [4M]
2. (a) Show that in deflected profile of a plate the planes carrying maximum slope and curvature cut orthogonal to each other. [7 M]
(b) Derive an expression for the strain energy stored in a plate subjected to transverse loading in terms of the deflection of the plate. State the assumptions made [7 M]
- 3.(a) Derive the differential equation for displacement of symmetrically loaded circular plate with uniformly distribute Load. The outer edge is fixed. [10 M]
(b) What is the difference in approach of Navier and Levy's solutions for thin plates analysis ? [4 M]
4. A thin simply supported circular plate of radius 'a' has a circular hole of radius 'b' and is subjected to a uniformly distributed load of 'q' per unit area. Derive the equation for deflection from first principles and determine the maximum radial and circumferential moments in the plate. [14 M]
5. (a) What are the various methods of bending analysis of cylindrical shell? Explain them briefly. [7 M]
(b) Derive differential equation by Schorer's theory to long cylindrical shell. [7 M]
- 6.(a) Explain the statistical checks that can be applied analyzing a cylindrical shell roof [4 M]
(b) Find expressions for membrane forces developed in a parabolic cylindrical shell roof subjected to a load 'g' per unit area of surface. [10 M]
7. (a) Derive the governing equation of shells of translation in Which only membrane forces can develop. [7 M]
(b) Develop the equation for membrane forces in a semicircular roof under its own weight supported at ends and free along the edges. [7 M]
8. Write short notes on any Two of the following: [2x7=14]
 - (i) Lamé's parameters and their significance
 - (ii) Bending analysis of cylindrical shell using Finster Walder method.
 - (iii) Membrane analysis of hyper shell.

[M16ST1201]

[M16ST1202]
I/II M.Tech. II Semester Regular Examinations
STRUCTURAL ENGINEERING
MODEL QUESTION PAPER
STRUCTURAL STABILITY

Time: 3 Hours

Max. Marks: 70

Answer any FIVE questions.
All questions carry equal marks.

1.(a) A column of rectangular cross-section, hinged at its ends, is acted upon by an axial load P. Using the double modulus theory, deduce an expression for the buckling load. [7 M]

(b) If the above column happens to be of an idealized I-section, derive an expression for buckling load using the double modulus theory. [7 M]

2. Derive expression for critical load of cantilever column under a constant load 'P' using Rayleigh-Ritz method. [14 M]

3. (a) Explain principle of conservation of energy. [7 M]

(b) Calculate the critical load for a column fixed at both ends of length 'l' and constant 'EI' using energy principle. [7 M]

4.(a) Explain Eigen value problem with reference to an axially loaded straight column. [7 M]

(b) With reference to stability of columns, beam columns and frames, explain discrete and continuous value interpretations. [7 M]

5. (a) Explain the finite difference method in the calculation of critical load in structural stability analysis. [7 M]

(b) Derive the expressions for critical load for the plate uniformly compressed in one direction. [7 M]

6. Show that the maximum deflection 'δ' of a bar under the simultaneously action of lateral load 'Q' and a longitudinal compressive force 'P' is given approximately by the expression. [14 M]

$$\delta = \left[\frac{\delta_0}{1 - \frac{P}{P_{er}}} \right] \text{ Where } \delta_0 \text{ is the maximum deflection}$$

Of the bar produced by lateral load 'Q' along and P is the critical load of the bar. How is the deflection magnified due to the action of the longitudinal compressive force?

7. Derive the equation for the mid height deflection of an initially bent column. [14 M]

8. Write short notes on the following topics:

[14 M]

(a) Effect of shear stress on buckling

(b) Buckling of plates

(c) Galerkin's method of stability analysis.

[M16ST1202]

[M16ST1203]
 I/II M.Tech. II Semester Regular Examinations
STRUCTURAL ENGINEERING
 MODEL QUESTION PAPER
FINITE ELEMENT METHODS OF ANALYSIS

Time: 3 Hours

Max. Marks: 70

Answer any FIVE questions.
 All questions carry equal marks.

1. (a) Explain about the application of finite element method. [7 M]
 (b) Write about strain-displacement relations. [7 M]
2. (a) Explain about two dimensional stress distribution. [7 M]
 (b) What are various elements that can be used in discretization of the structure? [7 M]
3. Derive element stiffness matrix for four noded Isoperimetric of the structure? [14 M]
4. (a) Obtain Strain displacement matrix for C.S.T element. [7 M]
 (b) Derive element stiffness matrix using the principle of potential energy, and obtain the element stiffness matrix for C.S.T element. [7 M]
5. (a) Derive shape functions for second order rectangular element. [7 M]
 (b) Write about compatibility requirement. [7 M]
6. A thin plate of uniform thickness 25mm is as shown in the figure 1. In addition to the self weight, the plate is subjected to a point load as shown. Analyses the plate after modeling with four elements and find displacement at various points, stresses at various points and support reaction. $E=2 \times 10^5 \text{ MPa}$, mass density $\delta=0.85 \times 10^{-4} \text{ N/mm}^3$.

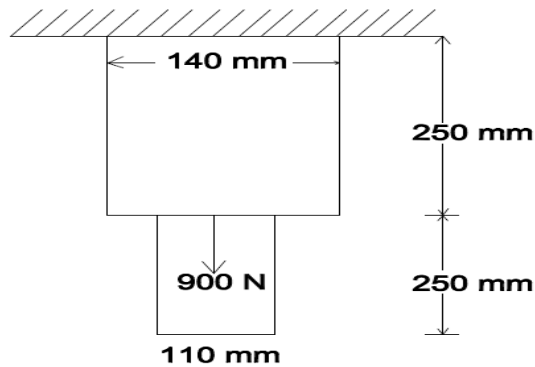

Figure 1

[14 M]

7. For the given truss, find noded displacements, support reactions and element stresses. $E=200 \text{ GPa}$, $A= 500 \text{ mm}^2$ for all elements. Also there is in temperature by $25 \text{ }^\circ\text{C}$. Coefficient of expansion $\alpha = 12 \times 10^{-6} / ^\circ\text{C}$. [14 M]

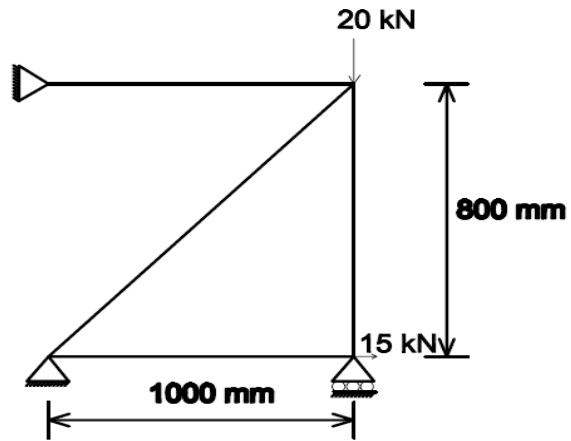

Figure 2

8. Write short notes on the following:

[14 M]

- (a) Gauss quadrature
- (b) Lagrange interpolation function
- (c) Displacement models

[M16ST1203]

[M16ST1204]
I/II M.Tech. I Semester Regular Examinations
STRUCTURAL ENGINEERING
MODEL QUESTION PAPER
EARTHQUAKE ENGINEERING

Time: 3 Hours

Max. Marks: 70

Answer any FIVE Questions
All questions carry equal marks.
Use of IS: 1893-2002 may be permitted.
Assume relevant additional data wherever required.

1. (a) Explain Epicenter, Hypocenter, Seismology and Earthquake. [7 M]
(b) Explain the terms strong motion, seismic regions and intensity of earthquakes. [7 M]
2. (a) Explain the construction steps of response spectrum. [7 M]
(b) Explain intensity of earthquakes and isoseismals of an earthquake. [7 M]
3. (a) Explain the construction steps of response spectrum. [7 M]
(b) Explain the concept of earthquake excitation? [7 M]
4. (a) Explain the influence of natural time period (T_1) and on higher mode response. [7 M]
(b) Explain the influence of beam to column stiffness ratio (P) on higher order response.
5. A 100 m high concrete gravity dam, shown in figure is located in seismic zone V for rocky (or) hard soil. Assume the velocity V_1 of longitudinal wave propagation in concrete be 3132 m/s and density of concrete as 2.5 T/m^3 . Calculate the Earthquake forces for unit thickness of dam using basic seismic coefficient method and also calculate hydrodynamic pressure. [14 M]

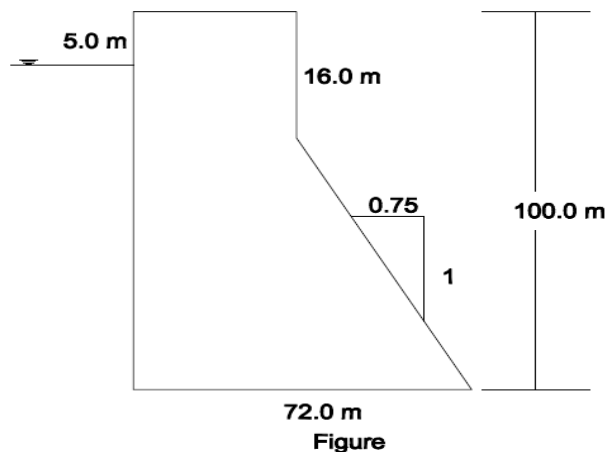

6. Write a detail note on:

- (a) Permissible increase in stresses and load factors for material stresses. [7 M]
- (b) Permissible increase in allowable bearing pressure of soils. [7 M]

7. Explain briefly the following terms: [14 M]
- (i) Drift
 - (ii) Torsion
 - (iii) Appendages
 - (iv) Dynamic analysis
 - (v) Effective weight
8. (a) Explain the importance of earthquake resistant construction of buildings and consideration of ductility provisions of reinforced concrete buildings. [14 M]
- (b) Explain with neat sketches provision of :
- (i) Horizontal reinforcement conditions, provisions.
 - (ii) Vertical reinforcement conditions, provisions.

[M16ST1204]

[M16ST1205]
 I/II M.Tech. II Semester Regular Examinations
STRUCTURAL ENGINEERING
 MODEL QUESTION PAPER
RELAIBILITY ANALYSIS AND DESIGN

Time: 3 Hours

Max. Marks: 70

Answer any FIVE Questions
 All questions carry equal marks.

1. (a) Samples of soil are collected from various depths below ground level and tested in the laboratory to determine their shear strength. The collected field data are given below [7 M]

Depth (m)	2	3	4	5	6	7
Shear Strength(kN/m ²)	14.8	20.3	32.2	39.0	42.0	56.4

Determine the sample covariance and correlation coefficient between depth of soil and its shear strength. What do you infer?

(b) Explain need for reliability analysis. [7 M]

2. (a) Consider the simply supported beam shown in figure. Assume the distributed load W , concentrated load P and the moment capacity M_R are uncorrelated normal random variables. Calculate the reliability index β . What is the probability that the beam will fail? The distribution parameters for the random variables are as below. [7 M]

$\mu_W = 1\text{kN/m}$ $V_w = 10\%$

$\mu_P = 10\text{kN}$ $V_p = 15\%$

$\mu_{MR} = 200\text{ kN/m}$ $V_{MR} = 12\%$

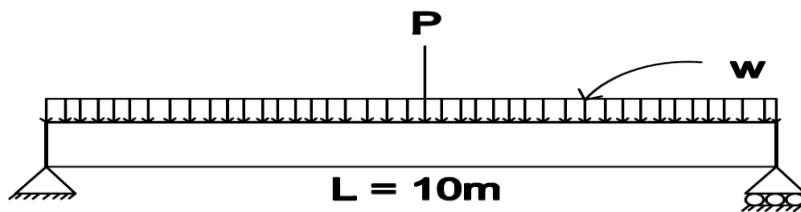

(b) The minimum annual flow Y in a river is assumed to follow type I external distribution. The mean and standard deviation of Y are $\mu_x = 5\text{m}^3/\text{S}$ $\sigma_x = 2\text{m}^3/\text{S}$ [7 M]

Calculate the probability of the minimum annual flow in a year being less than $2\text{m}^3/\text{Sec}$

3. It is given that the ratio of the mean value of the cube strength of M15 concrete to its characteristic strength is 1:4 and the coefficient of variation of the strength of the concrete is 0.18. Determine the allowable stress for the probability of failure equal to 10^{-3} . [14 M]

4. A reinforced concrete beam of an effective span 8m is subjected to live load. The cross section has been designed with M25 concrete and steel grade Fe 250. The area of steel is 1400mm^2 and the self weight of the beam is 3KN/m . It is given that the random variables the cube strength of concrete f_{ck} and yield strength of steel f_y are normally distributed

Breadth of beam = 240mm

Effective depth of beam = 480mm

Mean value of $f_{ck} = 30.28\text{MPa}$

Mean value of $f_y = 320\text{MPa}$

SD of $f_{ck} = 4.5\text{MPa}$

SD of $f_y = 32.0\text{MPa}$

Calculate the probability of failure of the beam if the live load (L) is normally distributed with mean 6KN/m and standard deviation 3KN/m . [14 M]

5. Calculate the reliability index for a steel tension member having tensile strength R subjected to a load ϕ . Given

$\mu_R = 280\text{MPa}$, $\sigma_R = 28\text{MPa}$

$\mu_Q = 5000\text{N}$

$\sigma_Q = 2000\text{N}$

$\mu_D = 6\text{mm}$

$\sigma_D = 0.6\text{mm}$

The member's circular in Cross section. [14 M]

6. Determine the reliability index of a simply supported I beam at the limit state of shear. The beam is subjected to a point load Q at mid span. It is given that

$\mu_Q = 4000\text{N}$

$\sigma_Q = 1000\text{N}$

$\mu_{fs} = 95\text{MPa}$

$\sigma_{fs} = 10\text{MPa}$

$\sigma_d = 2.5\text{mm}$, $d/t_w = 40$, $\mu_d = 50\text{mm}$

Where d is the depth of the beam, t_w thickness of web, f_s is the shear strength of the material. The coefficient of variation of t_w is negligible. [14 M]

7. The test results of compressive strength (N/mm^2) of 50 concrete cubes obtained from a building project are given below.

17.24	16.18	16.53	15.2	18.4
19.73	17.24	20.53	19.38	23.42
17.6	18.76	20	20.36	20.27
19.82	20.09	21.78	19.82	19.11
21.42	22.31	21.86	21.15	20.36
13.60	14.98	15.08	18.01	14.93
13.96	15.64	15.56	16.09	13.96
13.87	15.75	12.11	17.18	16.20
15.65	16.27	14.83	13.24	15.03
13.96	15.58	17.36	16.29	16.71

Calculate the mean, the standard deviation and the coefficient of the variation of the strength of concrete for the given data. Plot the histogram. Determine the chance of getting a value less than 15N/mm^2 . [14 M]

- 8 (a) Explain Monte Carlo method.
(b) Extreme type I distribution.
(c) Hasofer – Lind method.

[14 M]

[M16ST1205]

[M16ST1206]
I/II M.Tech. II Semester Regular Examinations
STRUCTURAL ENGINEERING
MODEL QUESTION PAPER
PRESTRESSED CONCRETE

Time: 3 Hours

Max. Marks: 70

Answer any FIVE Questions
All questions carry equal marks.
Use of IS: 1343 is permitted

- 1.a) What are the advantages of prestressed concrete over reinforced concrete? (7 M)
- b) Explain why high strength concrete and high tensile steel are used for prestressed concrete construction. (7 M)
2. A simply supported beam of prestressed concrete spanning over 10 m is of rectangular section 500 mm wide by 750 mm deep. The beam is prestressed by a parabolic cable having an eccentricity of 200 mm at the centre of span and zero at the end supports. The effective force in the cable is 1600 kN. If the beam supports a total uniformly distributed load of 40 kN/m, which includes the self-weight of the beam, a) Evaluate the extreme fibre stresses at the mid span section. b) Calculate the force required in the cable having the same eccentricity to balance a total load of 50 kN/m on the beam. (14 M)
3. A concrete girder of unsymmetrical I-section used for a bridge spans over 30 m and its self-weight is 10.8 kN/m. The girder is prestressed by a parabolic cable having an eccentricity of 580 mm at centre of span and 170 mm at supports towards the soffit of the girder. The initial force in the cable is 3200 kN. If loss ratio is 0.85 and the creep coefficient is 1.6, modulus of elasticity of concrete is 34 kN/mm², estimate the long term deflection of the bridge girder and compare it with the permissible deflection as per IS: 1343 code specifications. Assume second moment of area as 72490 x 10⁶ mm⁴ and live load is 9 kN/m. (14 M)
4. Design a suitable section for the tie member of a truss to support a maximum design tensile force 200 kN. The permissible compressive stress in concrete at transfer is 16 N/mm² and no tensile stresses are permitted under working loads. Loss ratio is 0.8. High tensile wires of 7 mm diameter tensioned to 1000 N/mm² is used. $f_p = 1600$ N/mm². The direct tensile strength of concrete is 3 N/mm². Load factor against collapse = 1.5 and load factor against cracking = 1.25. (14 M)
5. A prestressed concrete T beam is to be designed to support an imposed load of 4.4 kN/m over an effective span of 5 m. The T beam is made up of a flange 400 mm wide and 40 mm thick. The rib is 100 mm wide and 200 mm deep. The stress in the concrete must not exceed 15 N/mm² in compression and zero in tension at any stage. Check for the adequacy of the section provided, and calculate the minimum prestressing force necessary and corresponding eccentricity. Assume loss of prestress = 20%. (14 M)

6. The support section of a prestressed concrete beam, 100 mm wide and 250 mm deep, is required to support an ultimate shear force of 60 kN. The compressive prestress at the centroidal axis is 5 N/mm². The characteristic cube strength of concrete is 40 N/mm². The cover to the tension reinforcement is 50 mm. If the characteristic tensile strength of steel in stirrups is 250 N/mm², design suitable reinforcements at the section using the Indian standard code IS: 1343 recommendations. Given data: $b_w=100\text{mm}$, $h=250\text{mm}$, $d=200\text{mm}$, $V=60\text{kN}$ $f_{cp}=5\text{ N/mm}^2$, $f_{ck}=40\text{ N/mm}^2$, $f_{yk}=250\text{ N/mm}^2$ (14 M)

7. The end block of a post tensioned beam is 80mm wide and 160mm deep. A prestressing wire, 7 mm in diameter, stressed to 1200 N/mm² has to be anchored against the end block at the centre. The anchorage plate is 50mm by 50mm. The wire bears on the plate through a female cone of 20mm diameter. Given the permissible stress in concrete at transfer, f_{ci} as 20 N/mm² and the permissible shear in steel as 94.5 N/mm², determine the thickness of the anchorage plate. (14 M)

8. A continuous prestressed concrete beam ABC ($AB=BC=10\text{ m}$) has a uniform rectangular cross section with a width of 100 mm and depth of 300 mm. The cable carrying an effective prestressing force of 360 kN is parallel to the axis of the beam and located at 100 mm from the soffit. a) Determine the secondary and resultant moment at the central support B. b) If the beam supports an imposed load of 1.5 kN/m, calculate the resultant stresses at top and bottom of the beam at B. Assume $D_c = 24\text{ kN/m}^3$. c) Locate the resultant line of thrust through beam AB. (14 M)

[M16ST1206]

[M16ST1207]
I/II M.Tech. II Semester Regular Examinations
STRUCTURAL ENGINEERING
MODEL QUESTION PAPER
GROUND IMPROVEMENT TECHNIQUES

Time: 3 Hours

Max. Marks: 70

Answer any FIVE Questions
All questions carry equal marks.

- 1) a) What are the factors affecting compaction? [7 M]
b) Explain vibroflotation technique of densifying cohesionless soil? [7 M]
- 2) a) What do you understand by grout monitoring? [7 M]
b) Discuss briefly about categories of grouting? [7 M]
- 3) Explain the method of construction of stone columns and their suitability? [14 M]
- 4) a) Discuss briefly about sand drains? [7 M]
b) What are the advantages of strip drains over other vertical drains? [7 M]
- 5) Briefly discuss about lime stabilization and their engineering benefits? [14 M]
- 6) What is dewatering, explain the well point systems with neat sketches? [14 M]
- 7) a) What is ground anchor, explain basic components and applications of ground anchor? [7 M]
b) Discuss about cement lime columns and their applications [7 M]
- 8) Write a short notes on [14 M]

Soil nailing
Ascending grouting
Compaction control
Dewatering by electro-osmosis

[M16ST1207]

[M16ST1208]
I /II M.Tech. II Semester Regular Examinations
STRUCTURAL ENGINEERING
MODEL QUESTION PAPER
INDUSTRIAL STRUCTURES

Time: 3 Hours

Max. Marks: 70

Answer any FIVE Questions
All questions carry equal marks.
Use of relevant IS code may be permitted

1. (a) What is a Plastic hinge? Determine its length for a simply supported rectangular beam of span subjected to u.d.l over its entire span. [7 M]
(b) Determine the shape factor of a hollow circular section. [7 M]
2. Analyse the fixed –base portal frame loaded as shown in Figure 1 and determine the plastic moment capacity assuming the all the members have the same plastic moment of resistance M_p

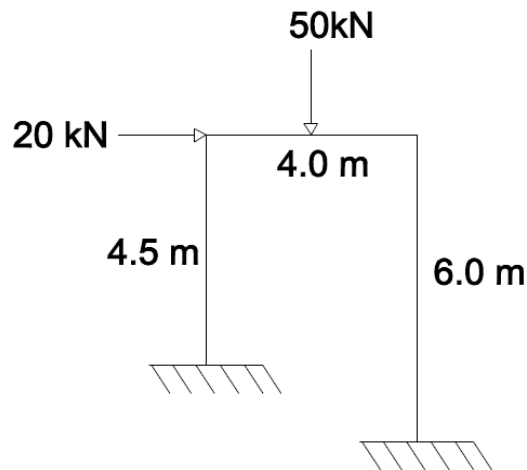

3. Determine the safe load carrying capacity of a column having rectangular box section 20 mm x 100 mm. The internal radius at corners is 2 mm. Thickness is 2 mm. The effective length of the column is 3 m. Take basic design stress 125 N/mm^2 . [14 M]
4. Two channel sections without bent lips 200 mm x 50 mm are connected with webs to act as a beam. The thickness of channel is 2.5 mm. The effective span of simply supported beam is 3.6 m. Determine the load inclusive of self weight that may be allowed on the beam. The beam is laterally supported throughout the span. Take $f_y = 235 \text{ N/mm}^2$. [14 M]
5. A 60 m high microwave antenna lattice tower is to be built at Visakhapatnam. The diameter of hemi-spherical antenna disc, provided at the top is 3 m. The minimum width of square platform is 3.0 m. Select a suitable truss configuration and determine the maximum forces in the legs of the tower and base shear. Assume any missing data appropriately. [14 M]
6. A self-supporting steel chimney is of height 60 m above the foundation. The diameter of the cylindrical part of the chimney is equal to 3 m. Design the plates for the chimney. The

thickness of brick lining is 100 mm. The topography at the site is flat and the location is of terrain category 2. The chimney is located in Hyderabad. [14 M]

7. Design a gantry girder for a mill building to carry an electric overhead travelling crane, having the following data: [14 M]

Crane capacity	=300kN
Weight of crane excluding crab	= 200 kN
Weight of crab	=50 kN
Span of crane between rails	=14m
Minimum hook approach	=1.2m
Wheel base	=3.2m
Span of gantry girder	=8m
Weight of rail section	=0.3 kN/m
Height of rail section	=75mm
Take $f_y=250 \text{ N/mm}^2$ and $E=2 \times 10^5 \text{ N/mm}^2$.	

8. Explain the following briefly: [14 M]

- (a) Concept of plastic analysis
- (b) Foundation for a chimney
- (c) Loads on transmission tower.

[M16ST1208]

[M16ST1209]
I/II M.Tech. II Semester Regular Examinations
STRUCTURAL ENGINEERING
MODEL QUESTION PAPER
DESIGN OF STEEL BRIDGES

Time: 3 Hours

Max. Marks: 70

Answer any FIVE questions.
All questions carry equal marks.

1. The effective span of a plate girder through type bridge for a single broad gauge track is 30m. the dead load, live load and impact load reaction is 1200 kN. The vertical reaction due to overturning effect of wind at each end of the girder is 80 kN. The lateral load due to wind at each bearing is 34 kN. Design the rocker bearing? [14 M]
2. A through type plate girder is provided for a single broad gauge track. The cross-girders are spaced 3m apart, the total span of the main girders from centre to centre of bearings being 30m. The stringers are spaced at 2m between Centre Line 0.6 kN per meter stock rails and 0.04 kN per metre check rails are provided Stringers are spaced at 450 mm from CK and are of Size of 2.8x250mmx250mm wt of sleeper(timber) may be assumed as 7.50 kN per cubic meter. Provided calculations for the max section of the main girder if EUDLL for B.M IS 2800 kN per track total for B.M, And EUDLL for shear 3023 kN per track, impact factor or 30 meters=0.45 . The main girders are provided at a spacing of 5m blue their certain lines . [14 M]
3. The effective Span of a through type truss girders highway through two lane bridge is 64m. The reinforced Concrete Slab is 250mm thick inclusive of the wearing coat. The foot paths are provided on either side of the carriage way. The spacing b/w centre to centre of tracks girders is 13m . Suggest a suitable truss girder for the bridge. Design the central member, the vertical and diagonal member of the central panel, design the Joint, where the central bottom chord, vertical and diagonal members. The high way bridge is to carry IRC class A standard loading. [14 M]
4. The effective span of a through plate girder bridge for a single broad gauge track is 30m. The depth of plate girder is 2664mm. The spacing blue the plate girders is 5.0m. The rail level is 800mm above the bottom of the girders. The net area of compression flange is 31983mm². The gross- moment of inertia of the plate girder section about xx-axis is 10761879.6x10⁴ mm² . Determine the increase of structure in the flanges of the leeward girder in the following cases: [14 M]
 - (a) Overturning effect due to behind when the bridge is unloaded.
 - (b) Horizontal truss effect due to wind, when the bridge is unloaded.
 - (c) Overturning effect due to wind where the bridge is loaded.
 - (d) Horizontal truss effect due to wind, when the bridge is loaded.Also , determine the percentage stress increment 9n care ©, if the dead load, live load and impact load reaction is 1210N.
5. The effective span of a plate girder deck type bridge for a single meter gauge track is 2m. The dead load, live load and impact load re4action is 700kN. The vertical reaction due to overturning effect of wind at each end of the girder is 100kN. Design a suitable bearing. [14 M]

6. A plate girder single track ,main line broad gauge is of 24m span blue bearings. Design a suitable section for the plate girder and calculate the curtailment of flanges. [14 M]
7. In a plate girder through bridge caring a single broad gauge track, the cross-girders are spaced at 4m centers, the stringers are spaced 2m centers. Design the stringers if their spacing blue main girder is 4mC/C. [14 M]
8. Explain briefly [14 M]
 - (a) Classification of steel bridge.
 - (b) Load for railways.
 - (c) Bearings.
 - (d) Plate girder bridges Vs Truss girder bridges.

[M16ST1209]

[M16ST1210]
I/II M.Tech. II Semester Regular Examinations
STRUCTURAL ENGINEERING
MODEL QUESTION PAPER
INELASTIC DESIGN OF SLABS

Time: 3 Hours

Max. Marks: 70

Answer any FIVE Questions
All questions carry equal marks.

1. a) Briefly explain assumptions made in Yield Line Theory and location of Yield Lines. 7M
b) Find the collapse load in a 7mX5m rectangular slab fixed at all edges for which the support moment capacities are the same as the midspan moment capacities in each direction. Assume $M_{px} = 0.25 M_{py}$, that is moment capacity in the long direction is 25% of that in the short direction? 7M
2. A rectangular slab 6mX4.5m, simply supported at its edge is to be designed as an isotropically reinforced slab to support a uniformly distributed working load of 18kN/m^2 which includes the self weight of the slab. Calculate the ultimate moment of resistance required for the slab section from the first principles? 14M
3. A rectangular slab 6mX8m, is supported on three edges and is free on one of the long edges. It carries a uniform load of 20kN/m^2 at collapse. Determine the moment capacities if the slab is isotropic with equal moment capacities in both directions. Also determine the effect of an additional line load of 30kN/m at collapse located along direction at 2m from the fixed long edge. 14M
4. Derive the expression for Rectangular Slab simply supported at three edges and free at the upper edge by using i) Virtual work method ii) Equilibrium method 14M
5. Derive virtual work equations only, for two-way slabs supported on four sides with different edge conditions having openings at centre, central eccentric, corner, central short side and central long side. 14M
6. Analyse rectangular slab supported on three (Balcony slabs) and four sides with different edge conditions using equilibrium method. 14M
7. A Square slab is simply supported on three sides and is free on the fourth side. Calculate the collapse load if moment capacity in x-direction is twice of that in the y-direction. How much more load can be supported by the slab, if all edges are simply supported and the moment capacities remain unchanged. 14M
8. A Rectangular slab 3.5mX5m in size simply supported at edges. The slab is expected to carry a service load of 3kN/m^2 and floor finish load of 1kN/m^2 . Use M20 concrete and Fe 415 steel. Design the slab if (i) it is isotropically reinforced (ii) if it is orthotropically reinforced with $\mu = 0.75$

[M16ST1210]